



Main

| | |
|---------------------------|---|
| Range of product | Altivar Process ATV900 |
| Product or component type | Variable speed drive |
| Device application | Industrial application |
| Device short name | ATV930 |
| Variant | Standard version With braking chopper |
| Product destination | Synchronous motors Asynchronous motors |
| Mounting mode | Wall mount |
| EMC filter | Integrated conforming to EN/IEC 61800-3 category C2 with 50 m motor cable maxi Integrated conforming to EN/IEC 61800-3 category C3 with 150 m motor cable maxi |
| IP degree of protection | IP21 conforming to IEC 61800-5-1 IP21 conforming to IEC 60529 |
| Degree of protection | UL type 1 conforming to UL 508C |
| Type of cooling | Forced convection |
| Supply frequency | 50...60 Hz (+/- 5 %) |
| Network number of phases | 3 phases |
| [Us] rated supply voltage | 380...480 V (- 15...10 %) |
| Motor power kW | 30 kW (normal duty) 22 kW (heavy duty) |
| Motor power hp | 40 hp (normal duty) 30 hp (heavy duty) |
| Line current | 53.3 A at 380 V (normal duty) 45.9 A at 480 V (normal duty) 40.5 A at 380 V (heavy duty) 35.8 A at 480 V (heavy duty) |
| Prospective line Isc | 50 kA |
| Apparent power | 29.8 kVA at 480 V (heavy duty) 38.1 kVA at 480 V (normal duty) |
| Continuous output current | 61.5 A at 4 kHz (normal duty) 46.3 A at 4 kHz (heavy duty) |

Disclaimer: This documentation is not intended as a substitute for and is not to be used for determining suitability or reliability of these products for specific user applications

| | |
|------------------------------------|---|
| Maximum transient current | 69.5 A during 60 s (heavy duty) 73.8 A during 60 s (normal duty) |
| Asynchronous motor control profile | Optimized torque mode Constant torque standard Variable torque standard |
| Synchronous motor control profile | Permanent magnet motor |
| Speed drive output frequency | 0.1...500 Hz |
| Nominal switching frequency | 4 kHz |
| Switching frequency | 2...16 kHz adjustable 4...16 kHz with derating factor |
| Safety function | STO (safe torque off) SIL 3 |
| Discrete input logic | 16 preset speeds |
| Communication port protocol | Ethernet/IP Modbus serial Modbus TCP |
| Option card | Slot A : communication module for Profibus DP V1 Slot A : communication module for Profinet Slot A : communication module for DeviceNet Slot A : communication module for CANopen daisy chain RJ45 Slot A : communication module for CANopen SUB-D 9 Slot A : communication module for CANopen screw terminals Slot A : communication module for EtherCAT Slot A/slot B/slot C : digital and analog I/O extension module Slot A/slot B/slot C : output relay extension module Slot B : 5/12 V digital encoder interface module Slot B : analog encoder interface module Slot B : resolver encoder interface module |

Complementary

| | |
|-------------------------------------|--|
| Output voltage | <= power supply voltage |
| Motor slip compensation | Adjustable Automatic whatever the load Not available in permanent magnet motor law Can be suppressed |
| Acceleration and deceleration ramps | S, U or customized Linear adjustable separately from 0.01 to 9000 s |
| Braking to standstill | By DC injection |
| Protection type | Motor : thermal protection Motor : safe torque off Motor : motor phase break Drive : thermal protection Drive : safe torque off Drive : overheating Drive : overcurrent between output phases and earth Drive : overload of output voltage Drive : short-circuit protection Drive : motor phase break Drive : overvoltages on the DC bus Drive : line supply overvoltage Drive : line supply undervoltage Drive : line supply phase loss Drive : overspeed Drive : break on the control circuit |
| Frequency resolution | Display unit : 0.1 Hz Analog input : 0.012/50 Hz |
| Electrical connection | Line side, screw terminal : 25...50 mm ² (AWG 4...AWG 1) Motor, screw terminal : 25...50 mm ² (AWG 4...AWG 1) Control, screw terminal : 0.5...1.5 mm ² (AWG 20...AWG 16) DC bus, screw terminal : 25...50 mm ² (AWG 4...AWG 1) |
| Connector type | 2 RJ45 (on the control block) for Ethernet IP/Modbus TCP 1 RJ45 (on the control block) for Modbus serial |
| Physical interface | 2-wire RS 485 for Modbus serial |
| Transmission frame | RTU for Modbus serial |
| Transmission rate | 10/100 Mbit/s for Ethernet IP/Modbus TCP 4.8, 9.6, 19.2, 38.4 kbit/s for Modbus serial |

| | |
|---------------------------|--|
| Exchange mode | Half duplex, full duplex, autonegotiation for Ethernet IP/Modbus TCP |
| Data format | 8 bits, configurable odd, even or no parity for Modbus serial |
| Type of polarization | No impedance for Modbus serial |
| Number of addresses | 1...247 for Modbus serial |
| Method of access | Slave for Modbus TCP |
| Supply | External supply for digital inputs : 24 V DC (19...30 V) current \leq 1.25 mA (overload and short-circuit protection) Internal supply for reference potentiometer (1 to 10 kOhm) : 10.5 V DC \pm 5 % current \leq 10 mA (overload and short-circuit protection) Internal supply for digital inputs and STO : 24 V DC (21...27 V) current \leq 200 mA (overload and short-circuit protection) |
| Local signalling | 3 mono/dual colour LED for local diagnostic 5 dual colour LED for embedded communication status 2 dual colour LED for communication module status 1 red LED for presence of voltage |
| Width | 226 mm |
| Height | 673 mm |
| Depth | 274 mm |
| Product weight | 28 kg |
| Analogue input number | 3 |
| Analogue input type | Software-configurable voltage AI1, AI2, AI3 : 0...10 V DC impedance 30 kOhm, resolution 12 bits Software-configurable current AI1, AI2, AI3 : 0...20 mA/4...20 mA impedance 250 Ohm, resolution 12 bits |
| Discrete input number | 10 |
| Discrete input type | Programmable DI1...DI8 : 24 V DC (\leq 30 V) impedance 3.5 kOhm Programmable as pulse input DI7, DI8 0...30 kHz : 24 V DC (\leq 30 V) Safe torque off STOA, STOB : 24 V DC (\leq 30 V) impedance $>$ 2.2 kOhm |
| Input compatibility | Discrete input STOA, STOB : level 1 PLC conforming to EN/IEC 61131-2 Discrete input DI1...DI8 : level 1 PLC conforming to EN/IEC 61131-2 Pulse input DI7, DI8 : level 1 PLC conforming to IEC 65A-68 |
| Discrete input logic | STOA, STOB, positive logic (source) : $<$ 5 V (state 0) $>$ 11 V (state 1) DI1...DI8, positive logic (source) : $<$ 5 V (state 0) $>$ 11 V (state 1) DI1...DI8, negative logic (sink) : $>$ 16 V (state 0) $<$ 10 V (state 1) DI7, DI8, positive logic (source) : $<$ 0.6 V (state 0) $>$ 2.5 V (state 1) |
| Analogue output number | 2 |
| Analogue output type | Software-configurable voltage AQ1, AQ2 : 0...10 V DC impedance 470 Ohm, resolution 10 bits Software-configurable current AQ1, AQ2 : 0...20 mA impedance 500 Ohm, resolution 10 bits |
| Discrete output number | 2 |
| Discrete output type | Logic output DQ+ : 0...1 kHz (\leq 30 V) DC, $<$ 100 mA Programmable as pulse output DQ+ : 0...30 kHz (\leq 30 V) DC, $<$ 20 mA Logic output DQ- : 0...1 kHz (\leq 30 V) DC, $<$ 100 mA |
| Sampling duration | Discrete input DI1...DI8 : 2 ms (\pm 0.5 ms) Pulse input DI7, DI8 : 5 ms (\pm 1 ms) Analog input AI1, AI2, AI3 : 1 ms (\pm 1 ms) Analog output AQ1, AQ2 : 5 ms (\pm 1 ms) |
| Accuracy | Analog input AI1, AI2, AI3 : \pm 0.6 % for a temperature variation 60 °C Analog output AQ1, AQ2 : \pm 1 % for a temperature variation 60 °C |
| Linearity error | Analog input AI1, AI2, AI3 : \pm 0.15 % of maximum value Analog output AQ1, AQ2 : \pm 0.2 % |
| Relay output number | 3 |
| Relay output type | Configurable relay logic R1 : fault relay NO/NC electrical durability 100000 cycles Configurable relay logic R2 : sequence relay NO electrical durability 1000000 cycles Configurable relay logic R3 : sequence relay NO electrical durability 1000000 cycles |
| Refresh time | Relay output R1, R2, R3 : 5 ms (\pm 0.5 ms) |
| Minimum switching current | Relay output R1, R2, R3 : 5 mA at 24 V DC |
| Maximum switching current | Relay output R1 on inductive load (cos phi = 0.4 and L/R = 7 ms) : 2 A at 250 V AC Relay output R1 on inductive load (cos phi = 0.4 and L/R = 7 ms) : 2 A at 30 V DC Relay output R2, R3 on inductive load (cos phi = 0.4 and L/R = 7 ms) : 2 A at 250 V AC Relay output R2, R3 on inductive load (cos phi = 0.4 and L/R = 7 ms) : 2 A at 30 V DC Relay output R1 on resistive load (cos phi = 1) : 3 A at 250 V AC Relay output R1 on resistive load (cos phi = 1) : 3 A at 30 V DC Relay output R2, R3 on resistive load (cos phi = 1) : 5 A at 250 V AC Relay output R2, R3 on resistive load (cos phi = 1) : 5 A at 30 V DC |

| | |
|------------------------------------|--|
| Isolation | Between power and control terminals |
| Specific application | Process |
| IP degree of protection | IP21 |
| Discrete and process manufacturing | Food and beverage processing mixer Food and beverage processing conveyor Food and beverage processing shredder Hoisting process crane Marine thruster Marine winch Material working (wood, ceramic, stone, pvc, metal) press Material working (wood, ceramic, stone, pvc, metal) extruder Mining mineral and metal other application Oil and gas drilling rig Oil and gas progressive cavity pump Oil and gas rod pump Oil and gas swapping pump Oil and gas compressor for regasification Oil and gas separator Oil and gas other application Water and waste water separator |
| Power range | 30...50 kW 380...440 V 3 phases 30...50 kW 480...500 V 3 phases |
| Motor starter type | Variable speed drive |

Environment

| | |
|---------------------------------------|--|
| Insulation resistance | > 1 mOhm at 500 V DC for 1 minute to earth |
| Noise level | 71.5 dB conforming to 86/188/EEC |
| Power dissipation in W | 93 W (natural convection) at 380 V switching frequency 4 kHz 640 W (forced convection) at 380 V switching frequency 4 kHz |
| Volume of cooling air | 240 m ³ /h |
| Operating position | Vertical +/- 10 degree |
| THDI | <= 48 % from 80...100 % of load conforming to IEC 61000-3-12 |
| Electromagnetic compatibility | 1.2/50 µs - 8/20 µs surge immunity test level 3 conforming to IEC 61000-4-5 Electrical fast transient/burst immunity test level 4 conforming to IEC 61000-4-4 Electrostatic discharge immunity test level 3 conforming to IEC 61000-4-2 Radiated radio-frequency electromagnetic field immunity test level 3 conforming to IEC 61000-4-3 Conducted radio-frequency immunity test level 3 conforming to IEC 61000-4-6 |
| Pollution degree | 2 EN/IEC 61800-5-1 |
| Vibration resistance | 1.5 mm peak to peak (f = 2...13 Hz) conforming to IEC 60068-2-6 1 gn (f = 13...200 Hz) conforming to IEC 60068-2-6 |
| Shock resistance | 15 gn during 11 ms conforming to IEC 60068-2-27 |
| Relative humidity | 5...95 % without condensation conforming to IEC 60068-2-3 |
| Ambient air temperature for operation | -15...50 °C without derating 50...60 °C with derating factor |
| Ambient air temperature for storage | -40...70 °C |
| Operating altitude | 1000...4800 m with current derating 1 % per 100 m <= 1000 m without derating |
| Environmental characteristic | Chemical pollution resistance class 3C3 conforming to EN/IEC 60721-3-3 Dust pollution resistance class 3S3 conforming to EN/IEC 60721-3-3 |
| Standards | EN/IEC 61800-3 UL 508C EN/IEC 61800-5-1 IEC 61000-3-12 IEC 60721-3 IEC 61508 IEC 13849-1 EN/IEC 61800-3 (environment 1 category C2) EN/IEC 61800-3 (environment 2 category C3) |
| Product certifications | UL CSA TÜV REACH |
| Marking | CE |

Offer Sustainability

| | |
|----------------------------------|---|
| Sustainable offer status | Green Premium product |
| RoHS (date code: YYWW) | Compliant - since 1526 - Schneider Electric declaration of conformity Schneider Electric declaration of conformity |
| REACH | Reference not containing SVHC above the threshold Reference not containing SVHC above the threshold |
| Product environmental profile | Available Product environmental |
| Product end of life instructions | Available End of life manual |

Dimensions

Views: Front - Left - Rear

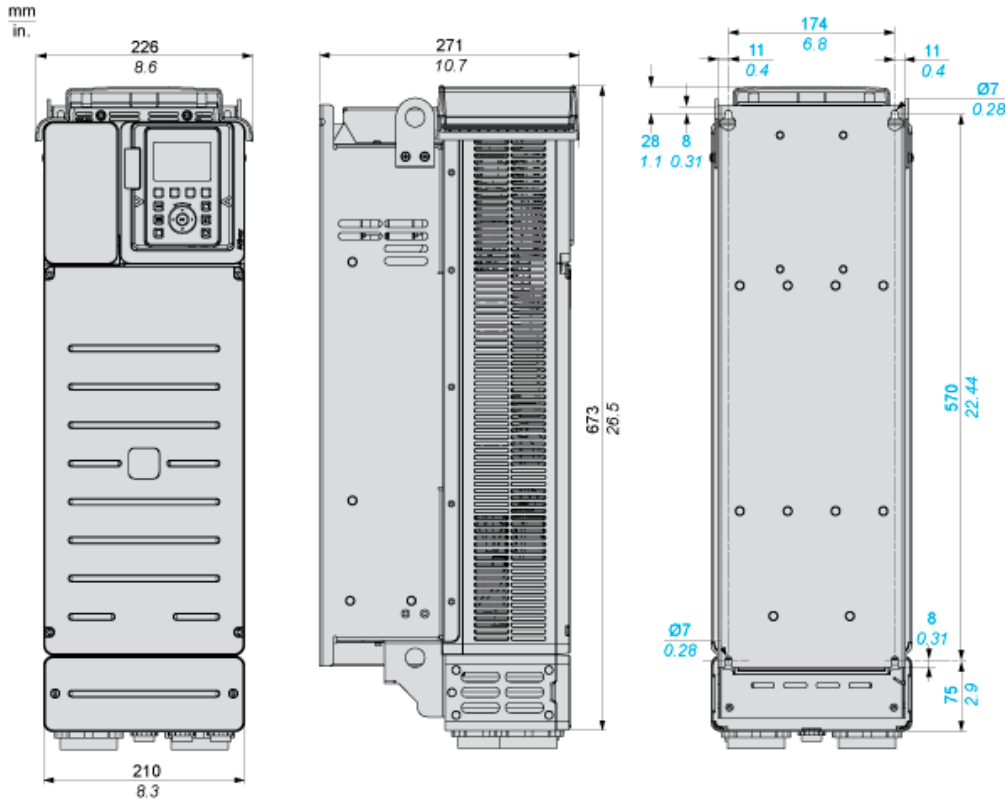

Clearances

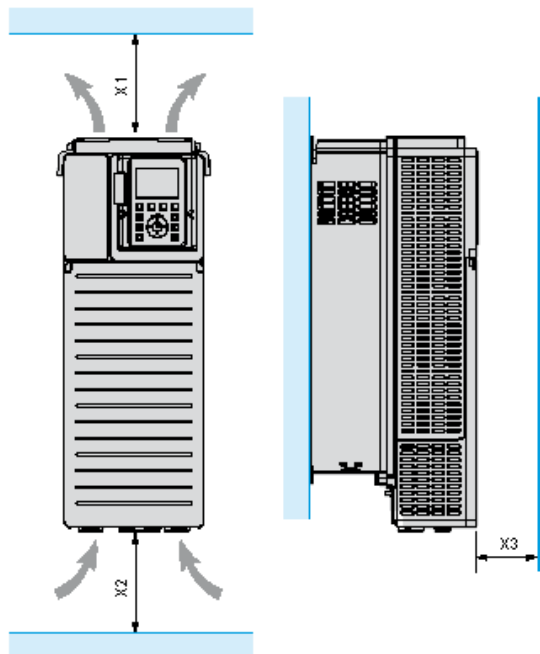

| X1 | X2 | X3 |
|---------------------|---------------------|--------------------|
| ≥ 100 mm (3.94 in.) | ≥ 100 mm (3.94 in.) | ≥ 10 mm (0.39 in.) |

- Mount the device in a vertical position ($\pm 10^\circ$). This is required for cooling the device.
- Do not mount the device close to heat sources.
- Leave sufficient free space so that the air required for cooling purposes can circulate from the bottom to the top of the drive.

Mounting Types

Mounting Type A: Individual IP21

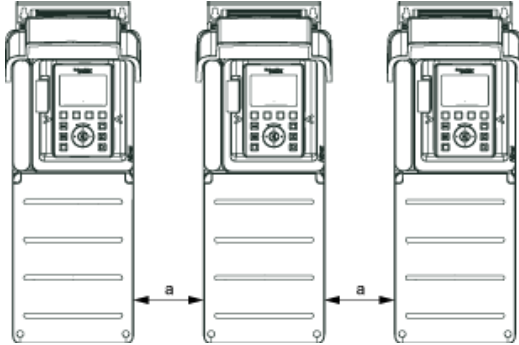

$a \geq 110 \text{ mm (4.33 in.)}$

Mounting Type B: Side by Side IP20 (Possible, 2 Drives Only)

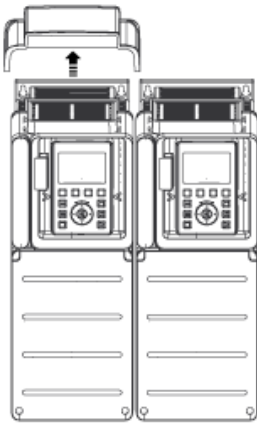

Mounting Type C: Individual IP20

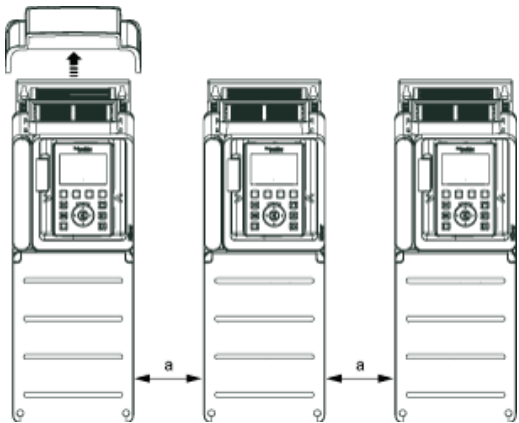

$a \geq 110 \text{ mm (4.33 in.)}$

Single or Three-Phase Power Supply with Upstream Breaking via Line Contactor

Connection diagrams conforming to standards EN 954-1 category 1 and IEC/EN 61508 capacity SIL1, stopping category 0 in accordance with standard IEC/EN 60204-1

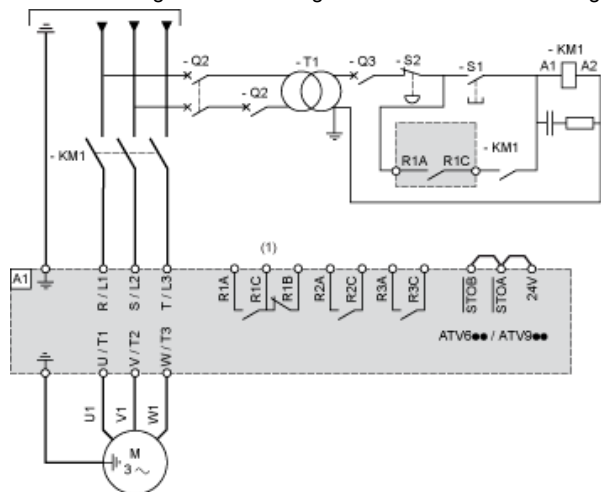

(1) Use digital output R1 set to operating state Fault to switch Off the product once an error is detected.

A1 : Drive

KM1 Line Contactor

Q2, Q3 Circuit breakers

S1, S2 Pushbuttons

T1 : Transformer for control part

Single or Three-Phase Power Supply with Downstream Breaking via Switch Disconnecter

Connection diagrams conforming to standards EN 954-1 category 1 and IEC/EN 61508 capacity SIL1, stopping category 0 in accordance with standard IEC/EN 6

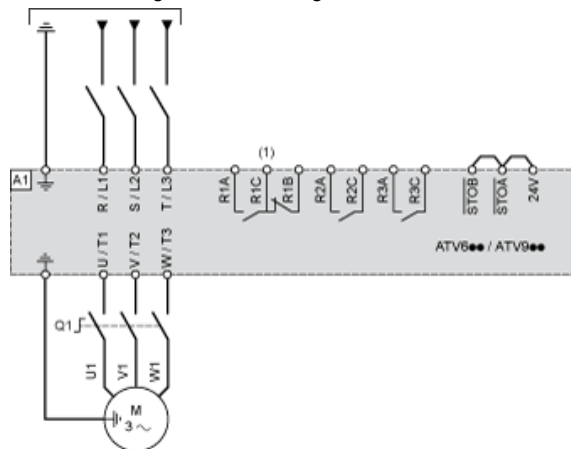

(1) Use digital output R1 set to operating state Fault to switch Off the product once an error is detected.

A1 : Drive

Q1 : Switch disconnector

Derating Curves

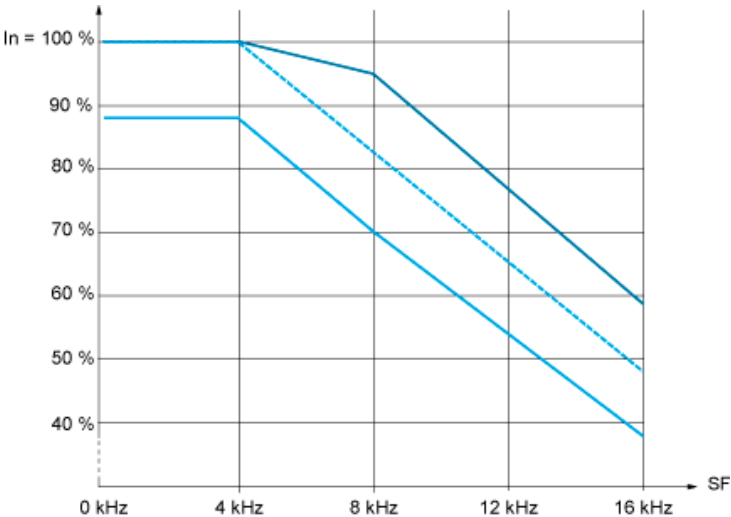

40 °C (104 °F) - Mounting type A, B and C
50 °C (122 °F) - Mounting type A, B and C
60 °C (140 °F) - Mounting type B and C
In : Nominal Drive Current
SF : Switching Frequency

Our Proposal: Circuit Breaker + Contactor + Drive for Motor Power 30 kW and 380 or 440 VAC

| Motor power (kW) | ICU (kA) | Breaker | Contactors (*) | Motor Starter BOM |
|------------------|----------|---|--|--|
| 30 | 50 |  GV3L65 |  LC1D50AP7 |  ATV930D30N4 |

Non contractual pictures.

Type 1 coordination requires that in a short-circuit condition, the contactor or starter must not present any danger to personnel or installations and must not be able to resume operation without repair or the replacement of parts.

(*) You can select the contactor proposed or variants. Please consider examples hereafter or follow the link to the complete offer.

| Motor power kW | Coil voltage VAC - 50/60 Hz | 24 | 48 | 110 | 115 | 220 | 230 | 400 | Other |
|----------------|-----------------------------|----|----|-----|-----|-----|-----|-----|----------------|
| 30 | LC1D50A .. | B7 | E7 | F7 | FE7 | M7 | P7 | V7 | Complete Offer |

| Motor power kW | Coil voltage VDC | 24 | 48 | 110 | 125 | 220 | 230 | Other |
|----------------|------------------|----|----|-----|-----|-----|-----|----------------|
| 30 | LC1D50A .. | BD | ED | - | - | - | - | Complete Offer |